

LSH-030-01-G-D-A



LSH-010-01-G-D-A



LSH-050-01-G-D-A



LTH-050-01-G-D-A



LTH-030-01-G-D-A



LTH-010-01-G-D-A



(0.50 mm) .0197"

LTH, LSH SERIES

LOW PROFILE BLADE AND BEAM

LTH Mates with:

LSH

LSH Mates with:

LTH

SPECIFICATIONS

For complete specifications and recommended PCB layouts see www.samtec.com?LTH or www.samtec.com?LSH

Insulator Material:

Liquid Crystal Polymer

Terminal Material:

Phosphor Bronze

Contact Material:

BeCu

Plating:

Au over 50µ" (1.27 µm) Ni

Operating Temp Range:

-55°C to +125°C

RoHS Compliant:

Yes

Processing:

Lead-Free Solderable:

Yes

SMT Lead Coplanarity:

(0.10 mm) .004" max

Board Stacking:

For applications requiring more than two connectors per board, contact ipg@samtec.com



-010, -020, -030, -040, -050

-G
= 10µ" (0.25 µm)
Gold

-K
= (5.50 mm) .217" DIA
Polyimide Film
Pick & Place Pad

-TR
= Tape and Reel

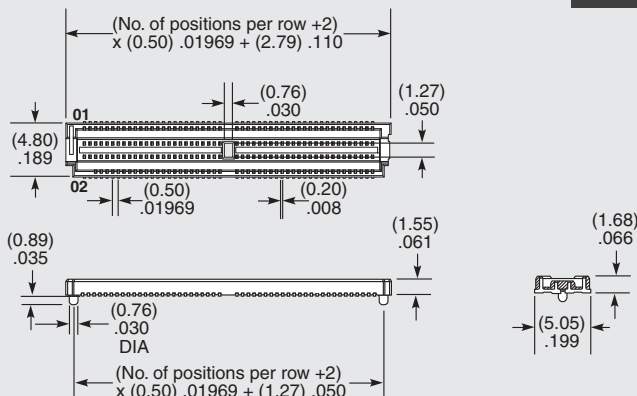

RECOGNITIONS

For complete scope of recognitions see www.samtec.com/quality



FILE NO. E111594



-010, -020, -030, -040, -050

-G
= 10µ" (0.25 µm)
Gold

-K
= (7.50 mm) .295" DIA
Polyimide Film Pick &
Place Pad

-TR
= Tape and Reel

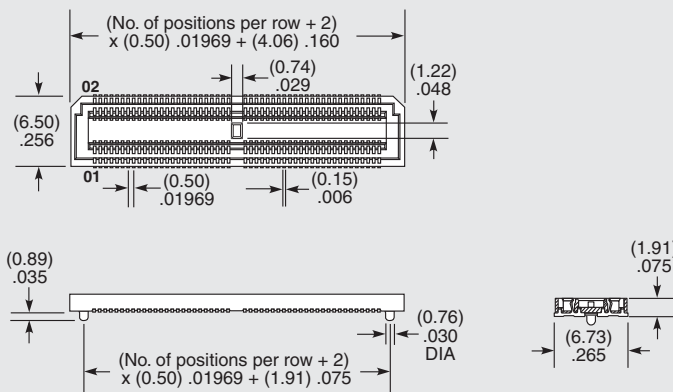

MATED HEIGHT

LEAD STYLE	MATED HEIGHT*
-01	(2.31) .091

*Processing conditions will affect mated height.

Note: Some lengths, styles and options are non-standard, non-returnable.